



TECHNICAL SPECIFICATIONS

TRANSFORMATÖR ELEKTROMEKANİK SAN. TİC. A.Ş.
Acıdereosb Mah. Çanakkale Cd. No: 11
Sarıçam / ADANA / Tl: 444 71 01
Faks: 0 322 394 42 55 / Mersis No: 085911562390001
Yüreğir V.D. 859 115 6239

Liquid Filled Hermetically Sealed Transformer

Elc. Eng. Kutluhan UÇAR

24.08.2022

ELECTRICAL DATA

Rating Power:	1000	kVA
Service:	Distribution	
Cooling:	ONAN	
Frequency:	50	Hz
Phase Number:	3	
Insulation Liquid:	Mineral Oil	
Type of Transformer:	<input checked="" type="checkbox"/> Hermetically Sealed <input type="checkbox"/> Oil Conservatory	
Standards:	IEC 60076	
Primary Voltage:	10 (Delta)	kV
Secondary Voltage:	0,4 (Star+N)	kV
High Voltage Regulation (Off Load Tap Changer):	±2 x 2,5 %	(9500 - 9750 - 10000 - 10250 - 10500)
Vector Group:	Dyn5	
Insulation Level at Primary Side:	LI 75 / AC 28 / Um 12	kV
Insulation Level at Secondary Side:	LI - / AC 3 / Um 1,1	kV
Windings Insulation Class:	A	
Primary/Secondary Windings Conductor:	Aluminum / Aluminum	
Designed Max. Ambient Temperature:	40	°C
Oil/Windings Temperature Rise:	60 / 65	K
Altitude of Installation:	≤1000	mt
Installation:	Indoor	
Surface Treatment:	RAL 7033	
Tank Construct:	Corrugated Wall	
Performance Values:		
No Load Loss:	693	W
Load Loss:	7600	W
Short Circuit Impedance:	6	%
Transformer Overall Dimensions:		
Length:	1525	mm
Width:	1085	mm
Height:	1850	mm
Distance Base Center:	820	mm
Transformer Weights:		
Active:	2330	Kgs
Oil:	580	Kgs
Total:	3430	Kgs

TRANSFORMER ACCESSORIES

1. H.V. Plug-in Bushings 24 kV 250 A	10. Lifting Lugs
2. L.V. Porcelain Bushings 1 kV 2000 A	11. Oil Level Indicator
3. Earthing Terminals	12. Wheels
4. Thermometer Pocket	13.
5. Pressure Safety Valve	14.
6. Oil Filling Valve	15.
7. Off Load Tap Changer	16.
8. Oil Drain Valve	17.
9. Rating Plate	18.

Technical Remarks: Performance values are according to IEC 60076 and European Union.
Tests according to IEC 60076 (if not otherwise indicated)
Dimensions and weights are approximate and will be confirmed after PO.
Warranty referred at nominal power rating and nominal voltage ratio (the highest in case of double primary voltages)

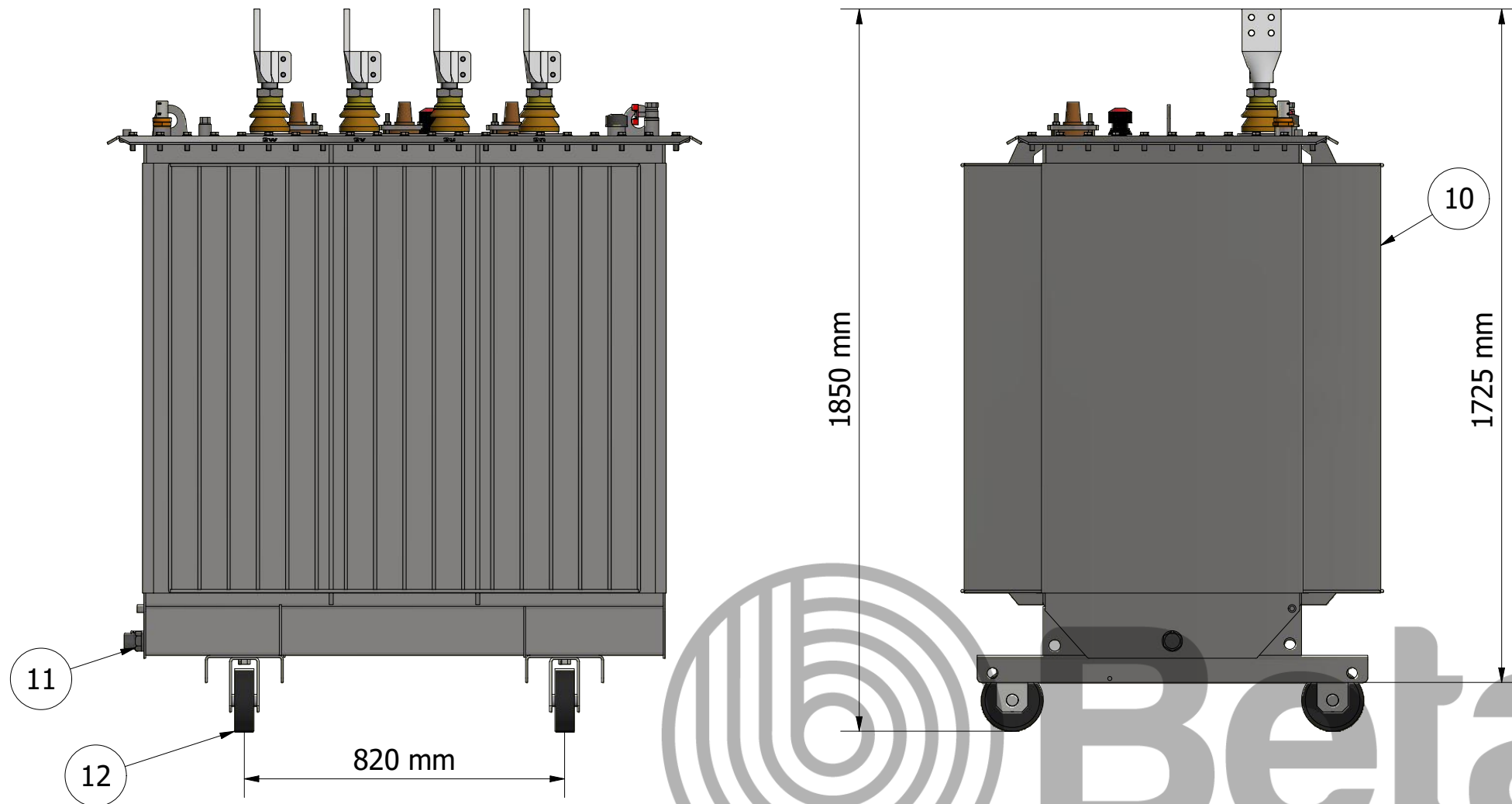

1000 kVA 10-0,4 kV		
NO	NAME	PCS
1	L.V. PORCELAIN BUSHING 1 kV 2000 A	4
2	H.V. PLUG-IN BUSHING 24 kV 250 A	3
3	OIL FILLING VALVE	1
4	PRESSURE SAFETY VALVE	1
5	OFF LOAD TAP CHANGER	1
6	THERMOMETER POCKET	1
7	OIL LEVEL INDICATOR	1
8	EARTHING TERMINAL	2
9	LIFTING LUGS	2
10	RATING PLATE	1
11	OIL DRAIN VALVE FOR MAIN TANK	1
12	WHEELS	4

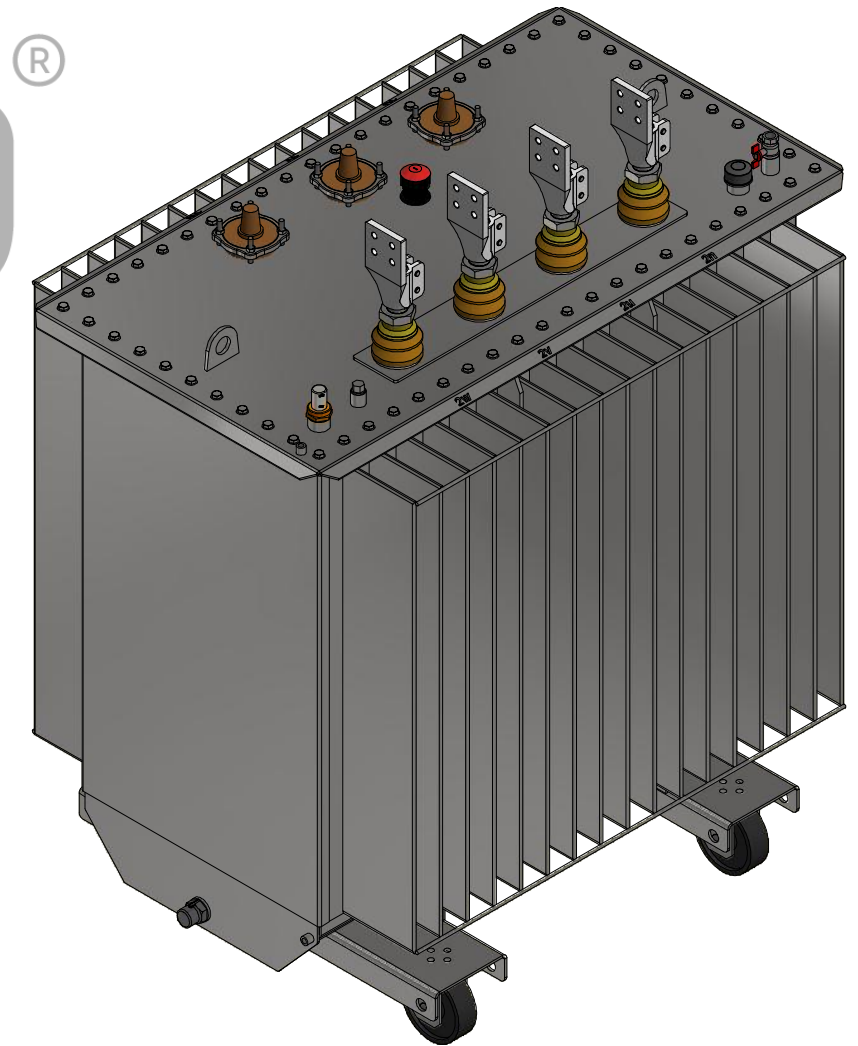
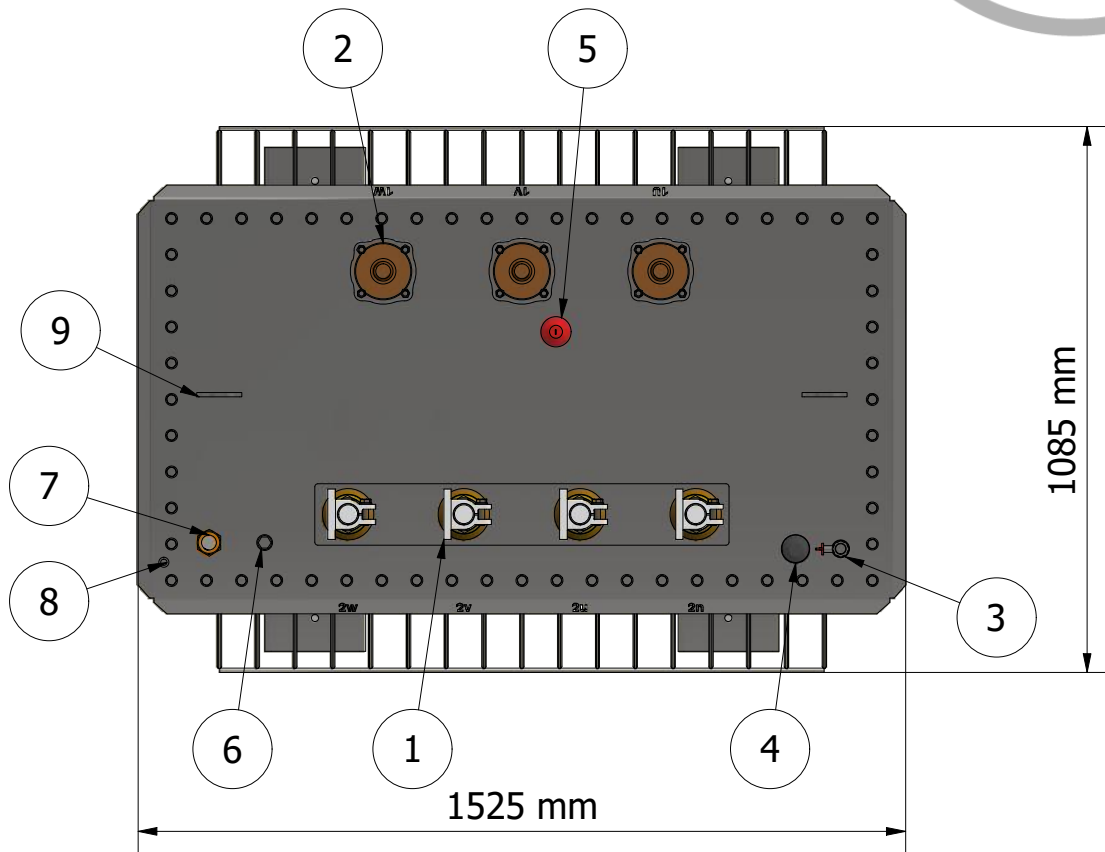

TRANSFORMATOR ELEKTROMEYKANİK SAN. VE TİC. A.Ş.
 Hacı Sabancı San. Böl. Çarşıbaşı Cad.
 No: 11-Bağcıbaşı Adana - Tel: 444 71 06
 Fax: 0322 384 42 55 - Mersis No: 0659115823000000
 Yüreğir V.D. 859 115 6239

TOTAL WEIGHT: 3430 Kgs
 ACTIVE WEIGHT: 2330 Kgs
 OIL WEIGHT: 580 Kgs

Dimensions and weights are approximate and will be confirmed after PO.				
M.Tasarımcı / M.Designer: S.YALAVAZ	M.Kontrol / M.Control: E.MAHMUTOĞLU	E.Tasarımcı / E.Designer: H.YILDIZ	Onaylayan / Approval: G.AKYILDIZ	Y.Tarihi / R.Date: 18.05.2022
Beta		1000 kVA 10-0,4 kV		